

Application and Standard

The 4-pole generator is suitable for matching with a reciprocating internal combustion engine (commonly called a diesel engine) to form a generator set, which can be used as a fixed power supply or backup power supply for national defense, post and telecommunications, airports, hospitals, buildings, oil exploration, industrial and mining enterprises and other departments.

Alternators are in compliance to the main domestic and international standards and regulations: GB755, BS5000, IEC60034, VDE0530, CSAC22.2-100, NEMAMG-1.22. Alternators' manufacturing, design and mark are carried out in the environment of ISO9001.

Electrical features

Automatic voltage regulators: 4 Pole Alternators are fitted with reliable and performant AVR, adapted to excitation systems, powered by transistors and fulfilling perfect regulation.

Short circuit capacity: two choices of excitation systems to meet different customer requirements:

- A) Self-Excitation system, without short-circuit capacity.
- B) PMG, with a short-circuit capacity of 3 times of the nominal current for 10seconds.

Transient features: Transient voltage dip for 60% rated current at 0.4 power factor is less than 15%. Recovery time for a 15% transient voltage dip is less than 1.5s.

Parallel operation: All 4 pole alternators can operate in parallel with other alternators or with the mains, when they are equipped with the appropriate devices (AVR, current transformer...).

Overload acceptance: 4 pole alternators can be overloaded according to NEMA.

Single-phase operation: 184 series 4 pole alternators can be connected for single phase use. 184 series alternators can be supplied with a dedicated single phase winding (D51/D61).

Waveform: Total harmonic distortion (THD), at no load or linear load is less than 5% according to IEC. Telephone influence factor (TIF) according to NEMA is less than 50.

Frequency: 4 pole alternators may operate either 50Hz or 60Hz. The standard winding (B31, B32) is suitable both for 50Hz and 60Hz.

Power factor: 4 pole alternators are designed to operate between 0.8 and 1.0 power factor. A derating is necessary below 0.8 power factor (see derating table).

Mechanical features

Forms: 4 pole alternators can be provided in single bearing or double bearing configurations according to customer's requirements, as well as Engine adaptors and coupling discs which are fit for the major engines.

Balancing: All the rotors are dynamically balanced according to ISO1940. Double bearing rotors are balanced with a half key.

Insulation and protection: 4 pole alternators are class H insulated. The standard winding protection can accept up to 95% relative humidity and is suitable in the cabins. Specific added coatings can be proposed for harsh environments.

Direction of rotation: 184 series can operate in both directions.

Terminal box and connectors: 4 pole alternators have a terminal box which allows easy access for connection of AVR or reconnection. Current transformers or other optional modules can be fitted with in the box.

Bearings: Sealed for life bearings up to all A4GEN 4 pole alternator.

Overs peed: The maximum overspeed is 2250rpm for the 4 pole alternator (1.25 times the 60Hz rated speed).

Mechanical structure: Steel frame. Cast iron or steel housing and flanges depending on models.

General parameters

Ambient temperature	40°C	Temperature rise	125K	Short circuit current multiple	/
Altitude	1000m	Voltage regulation	± 1%	Cooling method	IC01
Insulation class	Class H	Exciter system	Brushless self-excitation	Direction of rotation	Clockwise
Duty type	S1	Winding pitch	2/3	Maximum speed	2250rpm
Phases	3	Power factor	0.8	Protection grade	IP23
Number of poles	4	TIF	<50	Frequency	50/60Hz
AVR model	SX460	THF	<2%	THD	2.5%

Electrical parameters

50Hz/1500RPM		Standard Winding / Power Factor 0.8								Special winding	
Duty type/Temperature rise/Ambient		Cont./125K/40°C				Standby/163K/27°C				Cont./125K/40°C	
Phase		3-Phases				3-Phases				1-Phase	
Voltage	Y	380V	400V	415V	440V	380V	400V	415V	440V	220V/230V/240V	
	Δ	220V	230V	240V		220V	230V	240V		功率因素	
	YY				220V				220V	0.8	1.0
A4G184-31	kVA	31	31	31	30	35	35	35	32.7	21.3	25
	kW	25	25	25	24	28	28	28	26.1	17	25

* Only 12-wire alternator can be realized, other voltages please consult the factory.

60Hz/1800RPM		Standard Winding / Power Factor 0.8								Special winding	
Duty type/Temperature rise/Ambient		Cont./125K/40°C				Standby/163K/27°C				Cont./125K/40°C	
Phase		3-Phases				3-Phases				1-Phase	
Voltage	Y	416V	440V	460V	480V	416V	440V	460V	480V	220V/230V/240V	
	Δ	240V				240V				功率因素	
	YY	208V	220V	230V	240V	208V	220V	230V	240V	0.8	1.0
A4G184-31	kVA	33.6	35.9	37.5	37.5	37	39.5	41.3	41.3	24	28
	kW	27	28.8	30.0	30.0	29.6	31.6	33.0	33.0	19	28

* Only 12-wire alternator can be realized, other voltages please consult the factory.

Moment of Inertia & Efficiency

Model		KAL184E3
Inertia (1-Bearing) J	kgm ²	0.211
50Hz400V Efficiency (100% load)	%	86.2
60Hz440V Efficiency (100% load)	%	86.9

Reactance (%) - Time Constant (ms)

A4G184-31		50Hz @ 400V	60Hz @ 440V
Short circuit ratio	Kcc	0.44	0.37
Direct axis synchronous unsaturated reactance	X _d	229	272
Direct Axis Transient Saturation Reactance	X' _d	16.9	20.1
Direct Axis Subtransient Saturation Reactance	X'' _d	9.8	11.7
Quadrature axis Synchronous Unsaturated Reactance	X _q	130	155
Quadrature Subtransient Saturation Reactance	X'' _q	10.3	12.3
Negative sequence saturation reactance	X ₂	1.01	1.20
Zero sequence unsaturated reactance	X ₀	0.57	0.67
Short-circuit transient time constant	T' _d	8	8
Subtransient time constant	T'' _d	9.9	9.8
Open circuit time constant	T' _{do}	446	531
Armature time constant	T _a	24.0	22.8

Outline Drawing (Single Bearing)

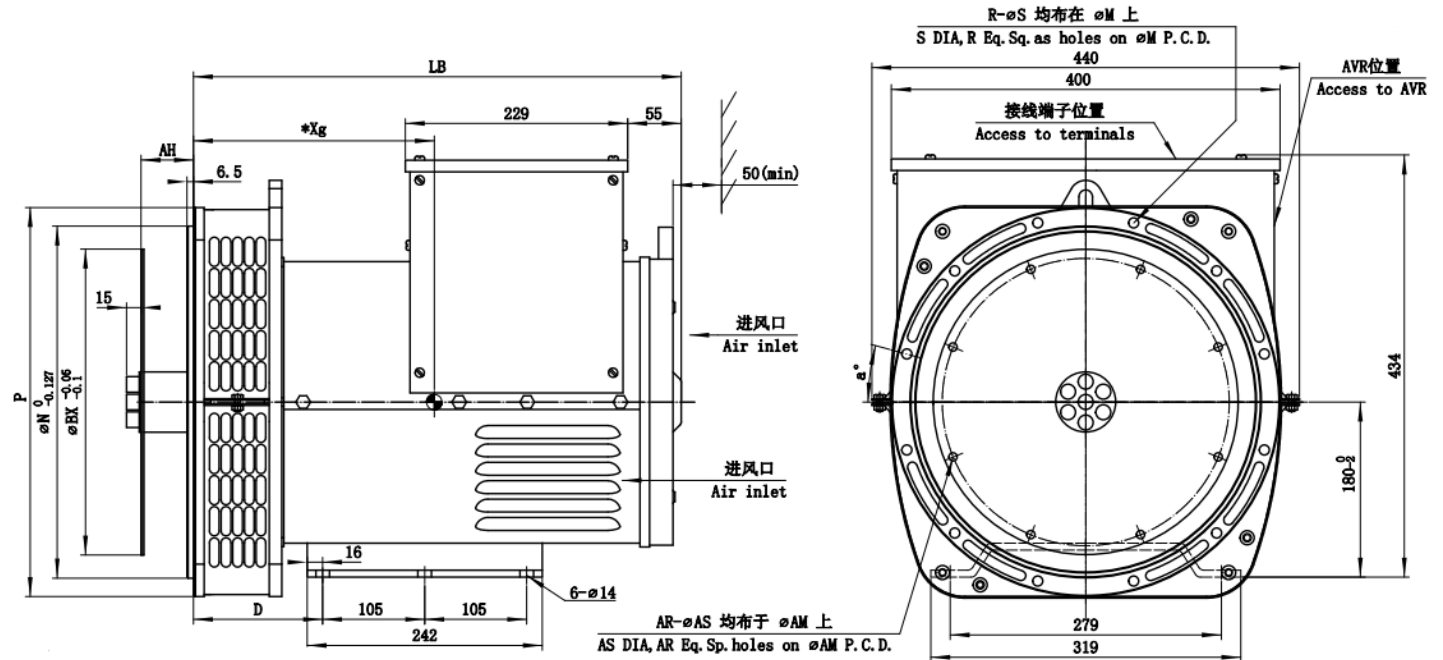

Dimension(mm)

TYPE	LB			*Xg	Weight	Package
	SAE2	SAE3	SAE4&5			
	mm	mm	mm			
A4G184-31	533	506	493.5	212	143	677*504*620

Flange (mm)

S.A.E	P	N	M	R- ϕS	W	D	a°
#2	490	447.675	466.725	12- $\phi 11$	6	172	15°
#3	440	409.575	428.625	8- $\phi 11$	6	145	15°
#4	400	361.95	381	8- $\phi 11$	5	133	15°
#5	400	314.325	333.375	8- $\phi 11$	5	133	22.5°

Coupling Disc (mm)

S.A.E	BX	AM	AR- ϕAS	AH
#6.5	215.9	200.025	6- $\phi 9$	30.2
#7.5	241.3	222.25	8- $\phi 9$	30.2
#8	263.525	244.475	6- $\phi 11$	62
#10	314.325	295.275	8- $\phi 11$	53.8
#11.5	352.425	333.375	8- $\phi 11$	39.6